

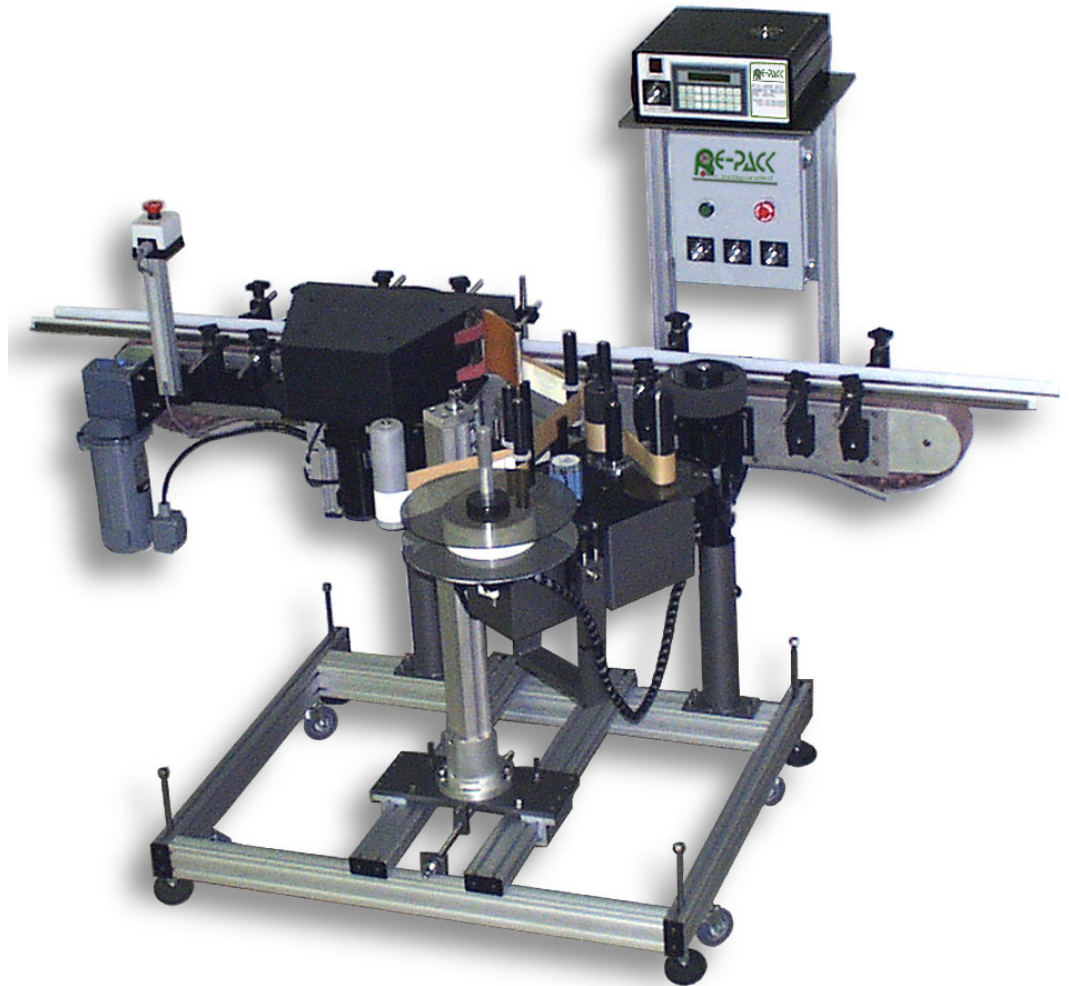

## "AccuWrap" Wrap Labeling System

This line of equipment is designed to wrap pressure sensitive labels around round products. With the addition of a modified wrap station and pressure plate, the machine can also label square and oval containers. A wide variety of options are available to include the following: Infeed handling devices, High speed drive packages and Bottle inspection systems.



Let  
Us  
Label  
You  
A  
Success

# Standard Features

- Series 4 Stepper driven, microprocessor controlled labeling head.
- Six (6) foot long stainless steel sided variable speed conveyor. The conveyor surface is made from a plastic "Rex" style chain. Longer conveyor lengths are available.
- Variable speed self-motorized wrap station. This device has a spring-loaded backing plate to allow for critical tension control. This ensures the containers will not be damaged during label application.
- Main electronics enclosure to include speed control, latching start button and emergency stop button.
- Adjustable guide rails. The guide rail holders have a "toolless" locking knob allowing for simple product changeover. The surfaces of the rails are made from a low friction, non-marring material.

# Available Options

- Clear label sensors to allow the use of transparent labels on a clear liner.
- Hot stamp date / lot coders.
- Larger web width kits and larger diameter unwind kits are available.
- Inspection devices such as, barcode readers and vision systems.

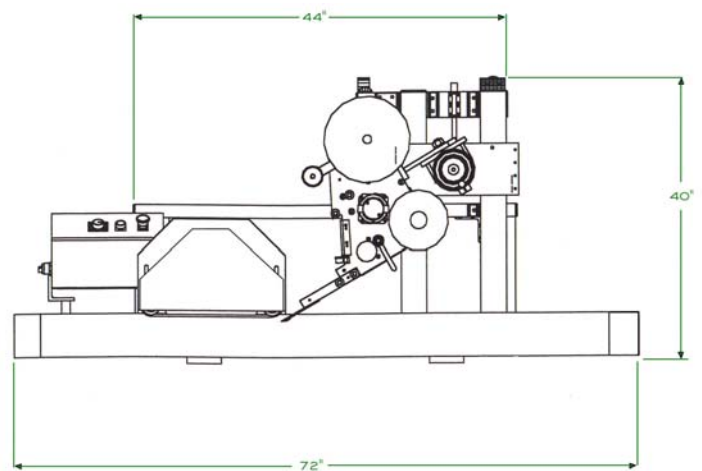
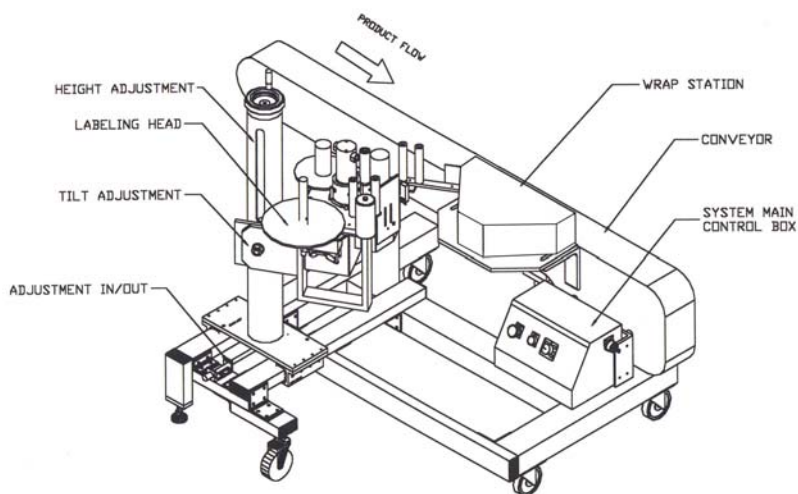

432 Industrial Drive  
North Wales, PA 19454  
Tel: (215) 699-9252  
[www.Re-Pack.com](http://www.Re-Pack.com)

**Contact your local  
Sales & Service  
Representative at:**

